



Pro-Tech Sno Pusher® Owner's Guide



FPL (loader) and FPB (backhoe) Models

SAFETY PRECAUTIONS

1. NEVER get under the unit during maintenance procedures without properly securing the unit
2. ALWAYS take a few minutes to properly secure the unit using dunnage or jack stands to ensure safety during maintenance.
3. DO NOT rely solely upon the hydraulics of your machine to secure the unit during maintenance.
4. NEVER get between the prime mover and the unit while attaching.
5. ALWAYS be sure to keep hands and feet away from designated pinch points.
6. DO NOT place hands or feet under the unit or the prime mover.
7. NEVER stand in front of a unit while prime mover is in operation.

OPERATING THE UNIT

The Pro-Tech Sno Pusher® is designed with several exclusive features to ensure safe and efficient snow removal. The heavy duty rubber cutting edge is combined with front and rear angled wear shoes. This minimizes potential damage to your machine by enabling the Sno Pusher to move over raised manhole covers, low curbs and other obstructions. At the same time you will maintain surface contact close enough for superior snow, flood and waste water removal purposes.

To ensure your unit will provide you with years of service with minimal maintenance follow these simple instructions:

1. Once the Sno Pusher is properly attached to your machine it MUST be leveled BEFORE plowing.
2. To level the unit set it down and adjust the curl of your bucket, making sure that BOTH wear shoes are resting squarely on your plowing surface. In addition, Pro-Tech also sells a level gauge and self-leveling shoes that assist in keeping the unit level.
3. To ensure proper contact drive your machine forward approximately 20', check surface area under your machine to ensure that plowing area is clean. If your plowing area is not completely clear, feel free to loosen the tension of binder(s) to allow your Sno Pusher to vertically adjust for maximum surface contact. Your Sno Pusher will not remove hard-pack. For hard-pack removal, see Pro-Tech's steel edge product lines.

IMPORTANT: Binders must be properly tightened prior to transportation or high speed use for FPL and FPB models.

4. DO NOT apply down force to the unit while plowing. This will considerably shorten the life of your wear shoes and this is NOT necessary for proper plowing.
5. When transporting the FPL or FPB, sides need to be folded. Each side has a locking bar attached to a pin on each side. Remove pins and locking bar and fold side in. Once side is folded, place locking bar over hole on the folded wing closest to the middle of the pusher and the hole that is on the middle piece of the pusher and place pins in to lock.

ATTACHING THE UNIT: FPL and FPB models

Attaching the Sno Pusher to your machine is made easy with Pro-Tech's Quick Change™ Design.

1. Drive the cutting edge of machine's bucket into the post receptacle on the back of the Sno Pusher. (Figure 1a and 1b)



Figure 1a



Figure 1b

The bucket will come to rest against the 12" structural steel channel reinforcement. The upper posts will fit inside the bucket and should be centered. The lower posts will be positioned under the bucket.

2. Attach the chains and binders to secure the Sno Pusher to your machine.

INSTALLING THE BINDER KIT

1. Grab hooks are to be welded to the side or back corners of your machine's bucket. Grab hooks are labeled D and E in Figure 2.

The location you choose MUST allow chains to be positioned parallel to the ground when attached. This will ensure easy centering of the Sno Pusher to your machine.

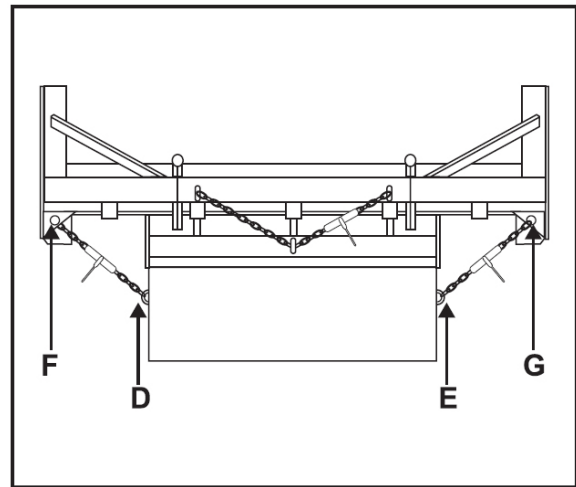

Figure 2

2. Attach one section of transport chain to both the right and left sides of the Sno Pusher by dropping a 3/8" clevis through each binder plate located in either side of the Sno Pusher. Binder plates are labeled F and G in Figure 2.

Leave enough slack in the chain to allow centering of the unit.

3. Weld the chain lug directly in the center on the top of your machine's bucket. (Chain Lug is labeled "C" in Figure 3) Slip the remaining transport chain through this center lug and connect to D-Rings "A" and "B" using the two remaining 3/8" clevis attachments.

Next, attach the last ratchet binder and tighten. This chain will remain attached during plowing and transport.

DO NOT connect this chain to the lifting lugs located above the D-Rings!

4. Your Sno Pusher is now secure and may be used for plowing or folded for road transport! (*Folding instructions are detailed for you in Figure 3*)
5. If your Sno Pusher is equipped for hydraulic operation, now connect the hoses to your machine with the flat faced coupler fittings.

For FPL & FPB, the optional Binder Kit Includes:

- 3 – 10' sections of 3/8" P-43 Transport Chain
- 2 – 5/16" Grab Hooks
- 3 – 3/8" Heavy Duty Ratchet Binder
- 4 – 3/8" Clevis Attachments
- 1 – Chain Lug

FOLDING THE UNIT

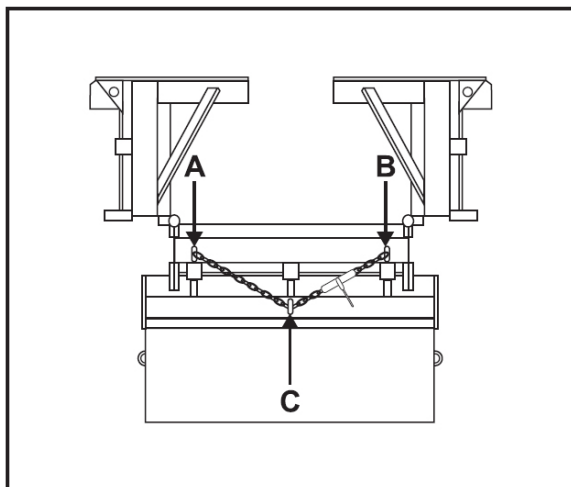

Figure 3

1. Detach both outboard chains by first releasing ratchet binders.
2. Remove locking pins at rear of left and right hinge.
3. Fold each wing forward approximately 90 degrees.
4. Once on site, open unit and replace pins.
5. You are now ready to start plowing.

MAINTENANCE

Your Pro-Tech Sno Pusher® requires only minimal service to remain in top condition. Follow these simple guidelines to ensure proper plowing and long life:

RUBBER

The heavy duty rubber cutting edge on every Sno Pusher has a symmetric design that is able to be adjusted for height, rotated and flipped. This provides (4) unique cutting edges ensuring long lasting performance.. On the FPL and FPB models this rubber is 1 1/2" x 10" thick. To ensure several years of service perform periodic inspections and adjustments following these simple guidelines:

IMPORTANT: A warm piece of rubber is much easier to adjust than one that is cold. It is highly recommended that your machine be placed in a warm place whenever making adjustments.

1. Always begin by placing the Sno Pusher on a smooth, flat surface when making any adjustments. Then place a 1/4 inch object under the wear shoes to raise the Sno Pusher a 1/4 inch above the level surface.
2. Loosen all bolts fastening the rubber to the Sno Pusher. It is NOT necessary to completely remove the bolts.
3. Using a large mallet or pry bar, adjust the rubber so that the rear, bottom edge just touches the ground.
4. Once rubber is properly positioned begin tightening the bolts. Starting in the center, work toward the side plates tightening the bolts enough to create a substantial bow in the 4" flatstock hold down.

IMPORTANT: We recommend using a 3/4" impact gun to ensure proper bolt torque (120 ft-lb).

WEAR SHOES

Every Sno Pusher is equipped with two hardened abrasion resistant bolt-on wear shoes that are replaceable to provide seasons of use by offering superior protection against wear and tear. When replacement is required, follow these guidelines:

1. Raise your Sno Pusher off the ground and secure the unit under the lower, rear receptacle posts and the side plate reinforcement angles using dunnage or jack standards.

2. Loosen all six bolts fastening the wear shoe to the unit and carefully remove.

IMPORTANT: Wear shoes are very heavy, please use caution during the removal and installation.

3. Position new wear shoe on left side and right side.
4. Install bolts, washers and locking nuts. Tighten bolts slightly, only enough to ensure that they won't fall off.
5. Lower unit on level surface and torque bolts (65-70 ft-lb) securely into place.

STORAGE

It is recommended that the fold-out unit is stored in the open or plowing configuration. If you need to store the unit in the closed or transport configuration you must support the rear of the unit to avoid damaging the rubber cutting edge. This can be done by supporting the unit beneath the lower posts. This will ensure that the rubber cutting edge is not compressed under the weight of the unit.

Store the pusher in a location out of direct sunlight and exposure to the weather to prevent premature degradation of the cutting edge.

Properly clean the unit before storage and remove dirt, debris, salt, etc. to extend paint life.

If the unit is power-washed, all lubrication points should be greased before storage.

LIMITED 10 YEAR WARRANTY

We will repair or replace any Pro-Tech Sno Pusher proven to be defective in materials or workmanship for ten years after the purchase date, in accordance with the following terms and conditions:

1. Pro-Tech reserves the right to determine whether a unit will be repaired or replaced.
2. Transfer of ownership to any party other than those mentioned on the original, returned warranty card or online registration will completely void this warranty.
3. All shipping and handling charges for returned units must be prepaid by the owner and received at the Pro-Tech facility FOB.
4. Shipping and handling charges may be avoided by submitting photographic evidence clearly showing the problem area and/or details of mechanical failure. (Note: We reserve the right to have a factory representative evaluate any problem(s) in the field.)

Pro-Tech makes no other warranty of any kind, either expressed or implied, including warranties pertaining to merchantability and fitness for a particular purpose.

This warranty is intended to provide you with specific rights, you may also have other rights which vary both internationally and domestically, as well as from state to state.

Warranty Coverage Procedure

1. Call Pro-Tech directly to discuss product information:
 - Serial #, Purchase Date, Proof of Purchase, Product Registration; product registered with Pro-Tech

2. Describe the nature of the warranty claim.
 3. Provide digital photographs illustrating the failure.
 4. Pro-Tech will determine if failure falls within the 10 year warranty. If it does, Pro-Tech will offer corrective options. If it does not, Pro-Tech will offer repair and cost options.
1. Please visit www.snopusher.com to register your unit online.

Exceptions to Warranty

1. Any wear associated with sacrificial parts such as:
 - Wear Shoes, Hardware, Cutting Edge
2. Any damage occurring as a result of:
 - Misuse, Negligence, Accidental Impact
3. Any non-factory repair or alteration deemed detrimental to the functionality of the Sno Pusher upon inspection by a Pro-Tech engineer will void all warranties specific or implied.

THE USE OF NON-PRO-TECH REPLACEMENT PARTS, SUCH AS RUBBER CUTTING EDGES OR WEAR SHOES, WILL VOID ALL WARRANTIES.

4. Pro-Tech will not be held liable for any personal damage that occurs as a result of use. This includes, but is not limited to:
 - Injury, Death, Loss of Use, Income or Profit Loss, Property Loss/Damage

PRODUCT REGISTRATION

In order for your new Sno Pusher to be covered under warranty you must register it with Pro-Tech. To register:



FPL and FPB
Owner's Guide