



Pro-Tech® Fusion Edge™ Sno Pusher Owner's Guide



SGL (Loader) and SGM (Compact Wheel Loader) Models

ABOUT PRO-TECH

Pro-Tech offers a robust product line of containment and multi-use plows to help its customers address multiple surface conditions and applications with confidence. Through quality, price and availability, Pro-Tech delivers proven value with durable, competitively priced products that are there when customers need them.

Quality, Price and Availability

Quality: Pro-Tech's values are trust, respect and quality based on integrity. We define integrity as consistency and credibility – and this applies not only to our products, but to our people as well. Our focus on integrity ensures that everything we do goes beyond the economics of business and stays consistent with our core values.

Quality is a measurement of our values translated through our word and our product. Our quality systems measure our performance with inspection processes and is maintained by a series of checks and balances and is reinforced with training.

With over 25 years of manufacturing and design experience and over 60,000 units sold - we confidently stand behind our product warranties.

Price: Quality and availability don't mean a whole lot if your product is priced out of reach for the majority of customers. At Pro-Tech, we feel we have the very best combination of Quality, Price and Availability. Our top quality products - with the Pro-Tech name, experience, warranty and integrity behind them – are priced fairly.

Combined with our Freight policy, our legendary durability, our turnkey mindset and our commitment to building relationships, our pricing guideline is just one of the many areas where we deliver more than is expected.

Availability: We believe customer satisfaction comes when the customer knows exactly what they are getting, when they are getting it and what it will cost. Our commitment to availability means that we build our inventory levels up during the winter season so we'll have product to ship when an order is placed.

We'll call you when your order is leaving the lot and our trucking partners will call you to confirm delivery times.

Our large distributor and dealer network ensures that large volumes of Pro-Tech products are available in multiple varieties across the United States and Canada.

SAFETY PRECAUTIONS

1. NEVER get under the unit during maintenance procedures without properly securing the unit
2. ALWAYS take a few minutes to properly secure the unit using dunnage or jack stands to ensure safety during maintenance.
3. DO NOT rely solely upon the hydraulics of your machine to secure the unit during maintenance.
4. NEVER get between the prime mover and the unit while attaching.
5. ALWAYS be sure to keep hands and feet away from designated pinch points.
6. DO NOT place hands or feet under the unit or the prime mover.
7. NEVER stand in front of a unit while prime mover is in operation.

OPERATING THE UNIT

The Pro-Tech Sno Pusher® is designed with several exclusive features to ensure safe and efficient snow removal. The Fusion Edge™ is an industry first combining the industry leading rubber edge with a hardened steel core. This gives superior surface results. The Pro-Float™ Coupler helps to reduce potential damage to your machine by enabling the Sno Pusher® to move over raised manhole covers, low curbs and other obstructions.

To ensure your unit will provide you with years of service with minimal maintenance follow these simple instructions:

1. Once the Sno Pusher is properly attached to your machine the cutting edge may be “broken-in” BEFORE plowing to achieve the best surface results. This process could take several hours before the steel edge is exposed.
2. To level the unit set it down and adjust the curl of your bucket, making sure that BOTH wear shoes are resting squarely on your plowing surface. In addition, Pro-Tech also sells a level gauge that can assist in keeping the unit level.
3. To ensure proper contact drive your machine forward approximately 20', check surface area under your machine to ensure that plowing area is clean. If using the post mount option and your plowing area is not completely clear, feel free to loosen the tension of binder(s) to allow your Sno Pusher to vertically adjust for maximum surface contact. Your Sno Pusher may not remove hard-pack in some instances.

IMPORTANT: Binders must not be tightened to a tension level that inhibits the movement of the Pro-Float™ Coupler.

4. Down force is NOT necessary for proper plowing. It can be added as required to assist in scraping hard packed snow. However, extended operation of down force will considerably shorten the life of your wear shoes and cutting edge.

FUSION EDGE™ BREAK-IN PROCEDURE

The Fusion Edge™ is a reversible cutting edge and comes in sectional pieces that have steel fully encapsulated in the rubber. (Figure 1a)

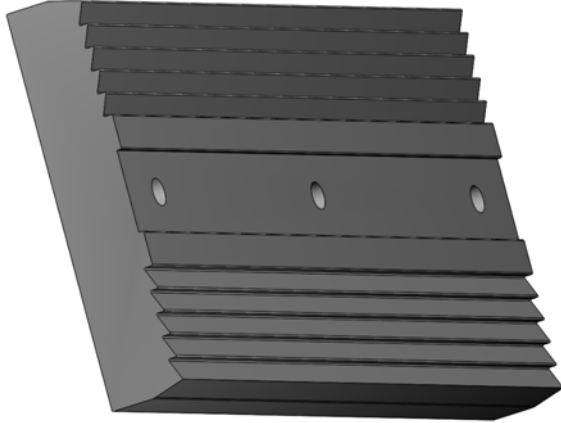

Figure 1a

Pro-Tech has designed the cutting edge by fully encapsulating the steel in the rubber to protect it from environmental elements before use. Prior to plowing, the cutting edge can be broken in to expose the steel component. (Figure 1b) This will optimize the surface outcome

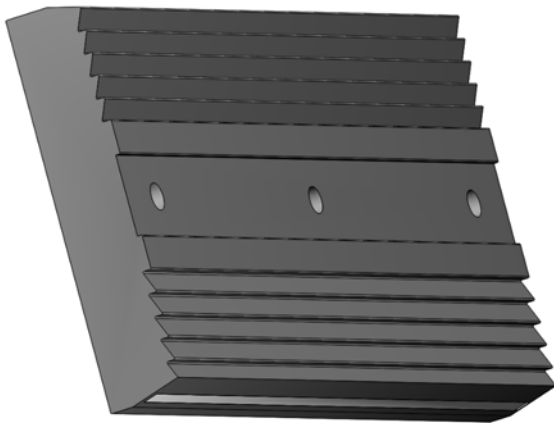

Figure 1b

If you choose to break-in prior to first use, this can be accomplished by hooking up the pusher to your prime mover and running it forward with moderate down pressure on a hard, dry concrete or asphalt surface for a minimum of 100 feet. Check the edges to see if the steel edges have been exposed and continue the break in process

as necessary. This procedure will need to be repeated when replacing or reversing the cutting edge.

ATTACHING THE UNIT: SGL and SGM models equipped with post configuration design

Attaching the Sno Pusher to your machine is made easy with Pro-Tech's Quick Change™ Design.

1. Drive the cutting edge of machine's bucket into the post receptacle on the back of the Sno Pusher. (Figure 2a and 2b)

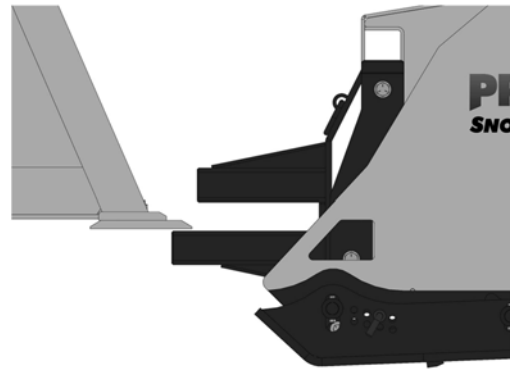

Figure 2a

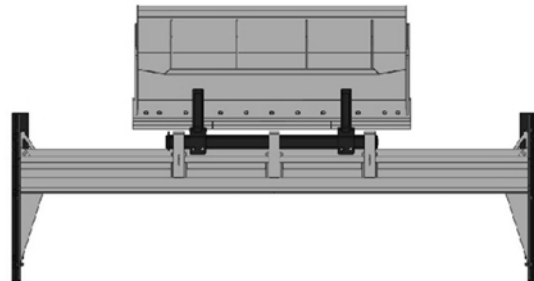

Figure 2b

The bucket will come to rest against the steel bucket stops. The upper posts will fit inside the bucket and should be centered. The lower posts will be positioned under the bucket.

2. Attach the chains and binders to secure the Sno Pusher to your machine.

INSTALLING THE BINDER KIT

1. Grab hooks are to be welded to the side or back corners of your machine's bucket.

The location you choose MUST allow chains to be positioned parallel to the ground when attached. This will ensure level operation of the Sno Pusher to your machine.

2. Attach one section of transport chain to the right side of the Sno Pusher using a 3/8" clevis. (Figure 3a)

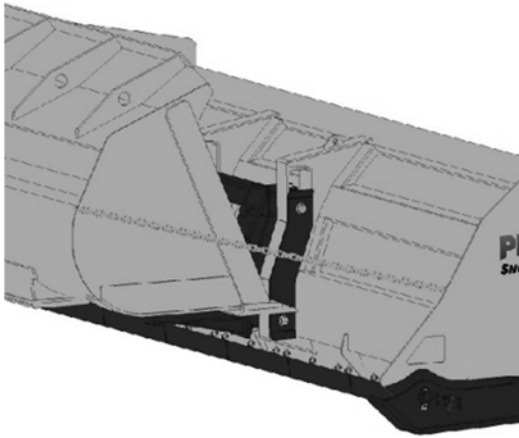

Figure 3a

Drop opposite end of this chain into grab hook on the right side of the bucket. Leave enough slack in the chain to allow centering of the unit and coupler.

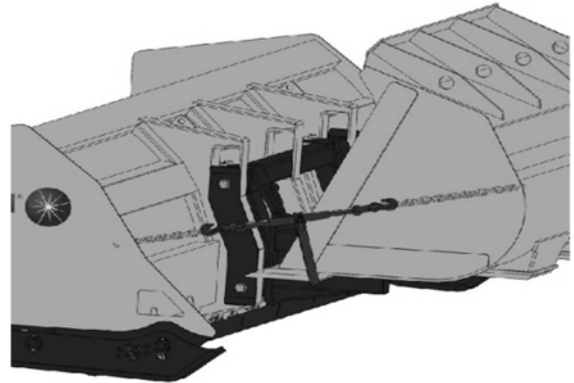

Figure 3b

3. Attach additional section of transport chain to the left side of the Sno Pusher using a 3/8" clevis.

Drop opposite end of this chain into grab hook on the left side of the bucket. Leave enough slack in the chain to attach the ratchet binder and allow centering of the unit. (Figure 3b)

4. Now that both chains are in place, you need to ensure full range of motion of the floating coupler while maintaining contact between your bucket and the inside of the post receptacles.

CAUTION: Do not use the lift hooks located at the top and rear of the Sno Pusher for chain attachment. These hooks are designed for lifting the unit only and not for plowing.

For SGL, Binder Kit Includes:

- 2 – 10' sections of 3/8" P-43 Transport Chain
- 2 – 5/16" Grab Hooks
- 1 – 3/8" Heavy Duty Ratchet Binder
- 2 – 3/8" Shackles

For SGM, Binder Kit Includes:

- 2 – 5' sections of 3/8" P-43 Transport Chain
- 2 – 5/16" Grab Hooks
- 1 – 3/8" Heavy Duty Ratchet Binder
- 2 – 3/8" Shackles

ATTACHING THE UNIT: SGL models equipped with a direct coupling system

Your Pro-Tech Sno Pusher® Loader Model (SGL) is equipped with the manufacturer's OEM Quick Coupler

1. Remove the bucket from your loader.
2. Drive machine into the coupler located on the back of the Sno Pusher®.
3. Engage the locking pins.

NOTE: The coupler assembly may need to be re-positioned to remain centered and aligned with prime mover.

ATTACHING THE UNIT: SGM model

Your Pro-Tech Sno Pusher® Compact Wheel Loader Model (SGM) is equipped with the manufacturer's OEM Quick Coupler

1. Remove the bucket from your compact wheel loader.
2. Drive machine into the adapter located on the back of the Sno Pusher.
3. Engage the locking pins.

MAINTENANCE

Your Pro-Tech Sno Pusher® requires only minimal service to remain in top condition. Follow these simple guidelines to ensure proper plowing and long life:

FUSION EDGE (Height Adjustment)

The height of Fusion Cutting Edge™ can be adjusted without any tools.

Raise unit off the ground to access the rear of the wear shoe. From the inside of the side plate locate and remove the lynch pin. (Figure 4a)

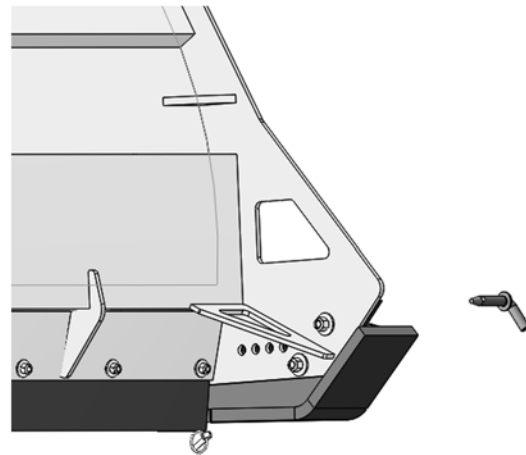
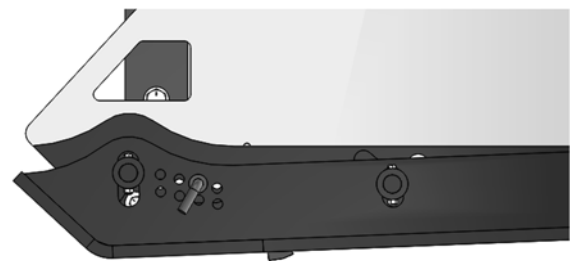

Figure 4a

Slightly raise the shoe upward to remove bearing weight on the shoe pin. Remove shoe pin and select desired adjustment position. Replace shoe pin and lynch pin. Repeat on opposite side maintaining the same hole height locations for each. Optimum position should not expose more than 1/2" of rubber edge.



FUSION EDGE (Replacement)

The cutting edge on every Pro-Tech Fusion Edge™ Sno Pusher has a symmetric design that can be reversed. This provides (2) unique cutting edges ensuring long lasting performance. The special designed Fusion Edge™ is 2" x 10" thick. To ensure several years of service perform periodic inspections and adjustments following these simple guidelines:

When a Fusion Cutting Edge™ section does need to be replaced due to wear or damage it can easily be changed out.



Figure 5a

1. Always begin by placing the Sno Pusher on a smooth, flat surface when making any adjustments.
2. Remove all bolts fastening the rubber to the Sno Pusher.
3. Reverse or replace the Fusion Edge™
Reinstall the hardware.
4. Once rubber is properly positioned begin tightening the bolts.

IMPORTANT: We recommend using a 1/2" impact gun to ensure proper bolt torque (55-65 ft-lb).

WEAR SHOES

Every Pro-Tech Sno Pusher® is equipped with two hardened, abrasion resistant, bolt-on wear shoes that are replaceable to provide seasons of use by offering superior protection against wear and tear. When replacement is required, follow these guidelines:

WARNING:

Wear shoes are extremely heavy, please use caution during the removal and installation process.

1. Lift Sno Pusher slightly off ground (2"-3") and secure before attempting any modifications.
2. Remove existing wear shoes by removing the shoe retaining bolts, lock nuts and collars. Then pull the wear shoe off the mounting pins.
3. Lubricate all sliding surfaces of the wear shoes, mounting pins, and retaining collars with grease or never-seize.
4. Re-install wear shoes by sliding them over the mounting pins and securing with the shoe retaining bolts, lock nuts and collars.

PRO-FLOAT COUPLER

The Pro-Float™ coupler should be lubricated at all contact points and the coupler hardware should be checked and tightened periodically to maintain full range of motion.

STORAGE

Store the pusher in a location out of direct sunlight and exposure to the weather to prevent premature degradation of the cutting edge.

Properly clean the unit before storage and remove dirt, debris, salt, etc. to extend paint life.

LIMITED 10 YEAR WARRANTY

We will repair or replace any Pro-Tech Sno Pusher® proven to be defective in materials or workmanship for ten years after the purchase date, in accordance with the following terms and conditions:

1. Pro-Tech reserves the right to determine whether a unit will be repaired or replaced.
2. Transfer of ownership to any party other than those mentioned on the original, returned warranty card or online registration will completely void this warranty.
3. All shipping and handling charges for returned units must be prepaid by the owner and received at the Pro-Tech facility FOB.
4. If the warranty claim can be diagnosed from photographs clearly showing the problem area and/or details of mechanical failure, the physical return along with additional shipping and handling charges may be avoided. (Note: We reserve the right to have a factory representative evaluate any problem(s) in the field.)

Pro-Tech makes no other warranty of any kind, either expressed or implied, including warranties pertaining to merchantability and fitness for a particular purpose.

This warranty is intended to provide you with specific rights, you may also have other rights which vary both internationally and domestically, as well as from state to state.

Warranty Coverage Procedure

1. Call Pro-Tech directly to discuss product information:
 - Serial #, Purchase Date, Proof of Purchase, Product Registration; product registered with Pro-Tech
2. Describe the nature of the warranty claim.

3. Provide photographs illustrating the failure.
4. Pro-Tech will determine if failure falls within the 10 year warranty. If it does, Pro-Tech will offer corrective options. If it does not, Pro-Tech will offer repair and cost options.

Exceptions to Warranty

1. Any wear associated with sacrificial parts such as but not limited to:
 - Wear Shoes, Hardware, Cutting Edge, Coupler Mounting Tubes, and connection points
2. Any damage occurring as a result of:
 - Misuse, Negligence, Accidental Impact
3. Any non-factory repair or alteration deemed detrimental to the functionality of the Sno Pusher upon inspection by a Pro-Tech engineer will void all warranties specific or implied.

THE USE OF NON-PRO-TECH REPLACEMENT PARTS, SUCH AS RUBBER CUTTING EDGES OR WEAR SHOES, WILL VOID ALL WARRANTIES.

4. Pro-Tech will not be held liable for any personal damage that occurs as a result of use. This includes, but is not limited to:
 - Injury, Death, Loss of Use, Income or Profit Loss, Property Loss/Damage

PRODUCT REGISTRATION

In order for your new Sno Pusher to be covered under warranty you must register it with Pro-Tech. To register:

1. Please visit www.protechcorp.com to register your unit online.

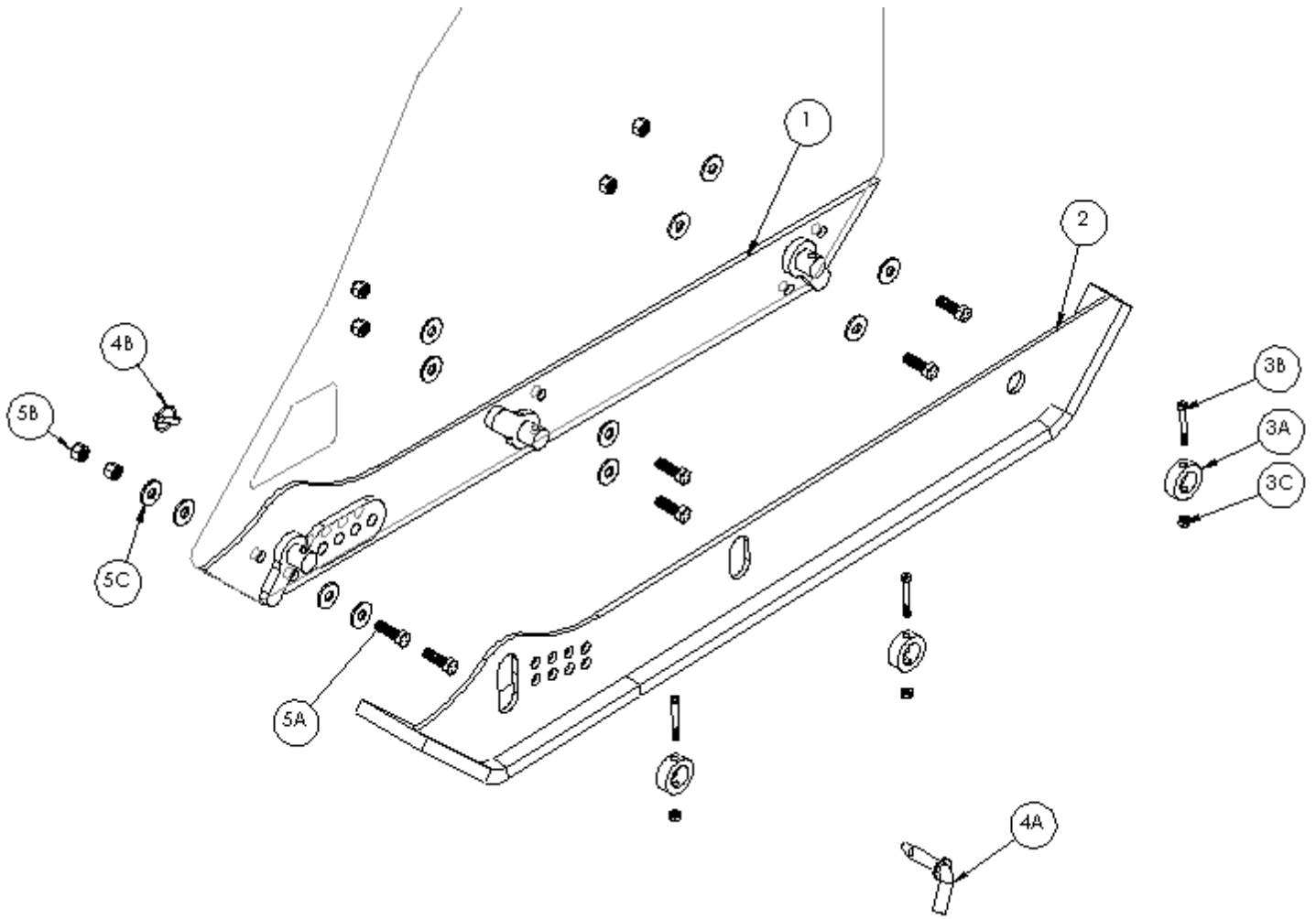

REPLACEMENT SHOES

ITEM	DESCRIPTION	QTY./UNIT
1	Mounting Web Assembly	2
2	Wear Shoe Assembly	2
3	Wear Shoe Retainer Assy	6
3A	Retaining Collar	6
3B	Bolt	6
3C	Nut	6
4	Shoe Pin Assy	2
4A	Shoe Pin	2
4B	Lynch Pin	2
5	Mounting Web Hardware	12
5A	Bolt	12
5B	Nut	12
5C	Washer	24

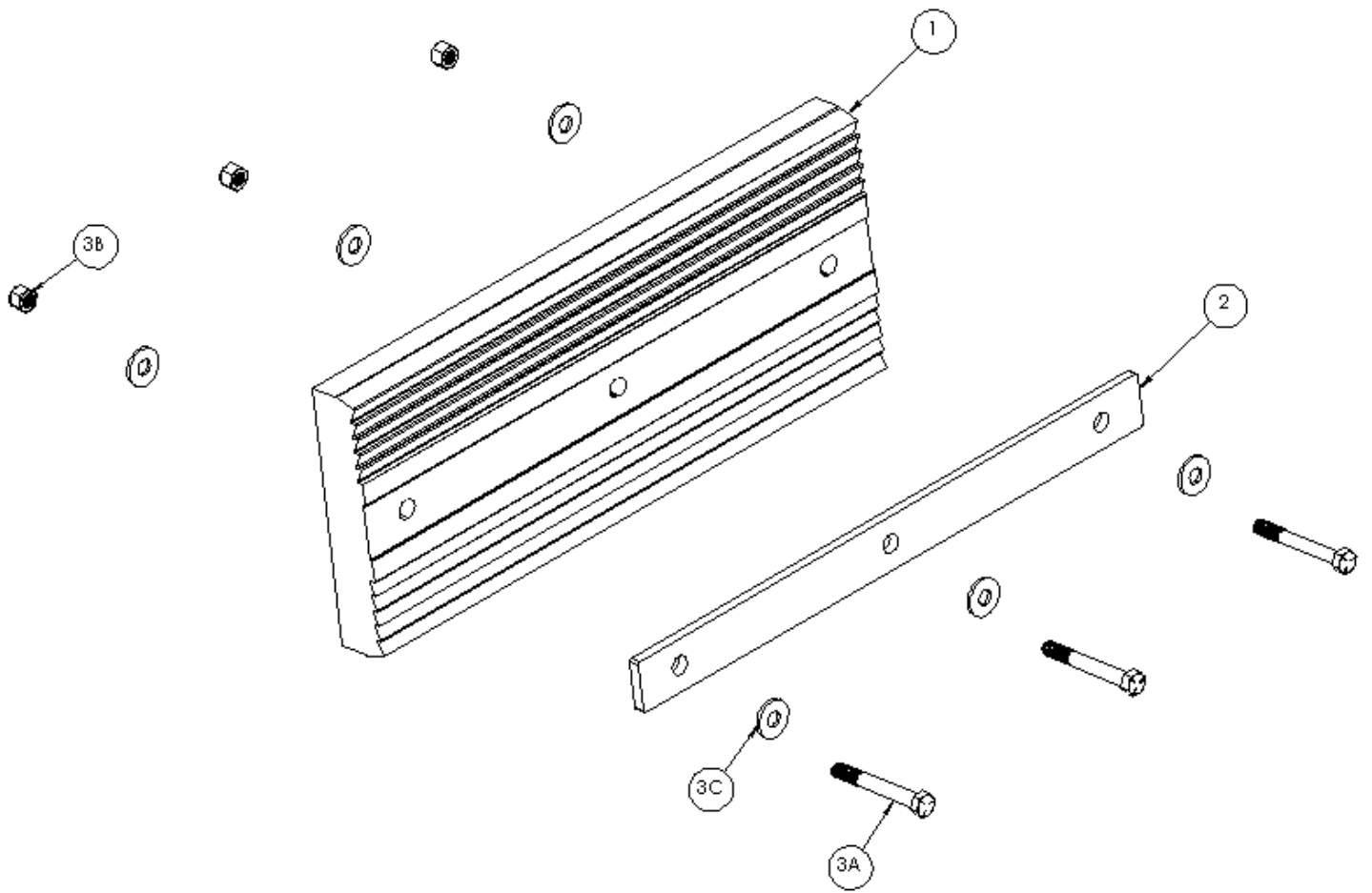

REPLACEMENT RUBBER

ITEM	DESCRIPTION	QTY./SECTION
1	Fusion Cutting Edge	1
2	Hold Down	1
3	Fusion Cutting Edge Mtg Hardware	3
3A	Bolt	3
3B	Nut	3
3C	Washer	6

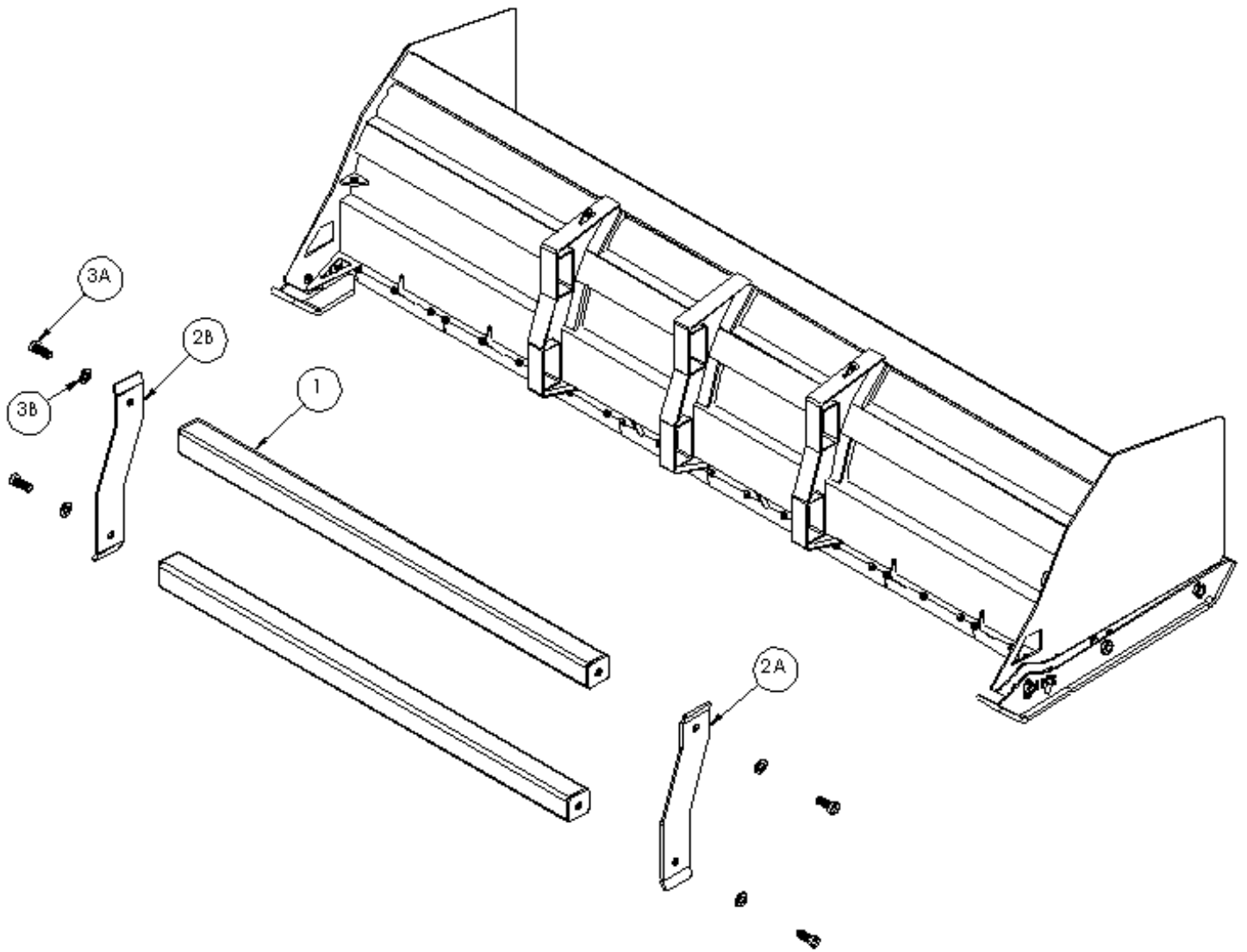

FLOATING COUPLER

ITEM	DESCRIPTION	QTY./UNIT
1	Coupler Mounting Tube	2
2A	Tube Side Bracket (Right)	1
2B	Tube Side Bracket (Left)	1
3	Coupler Mounting Tube Hardware	1
3A	Bolt	4
3B	Washer	4

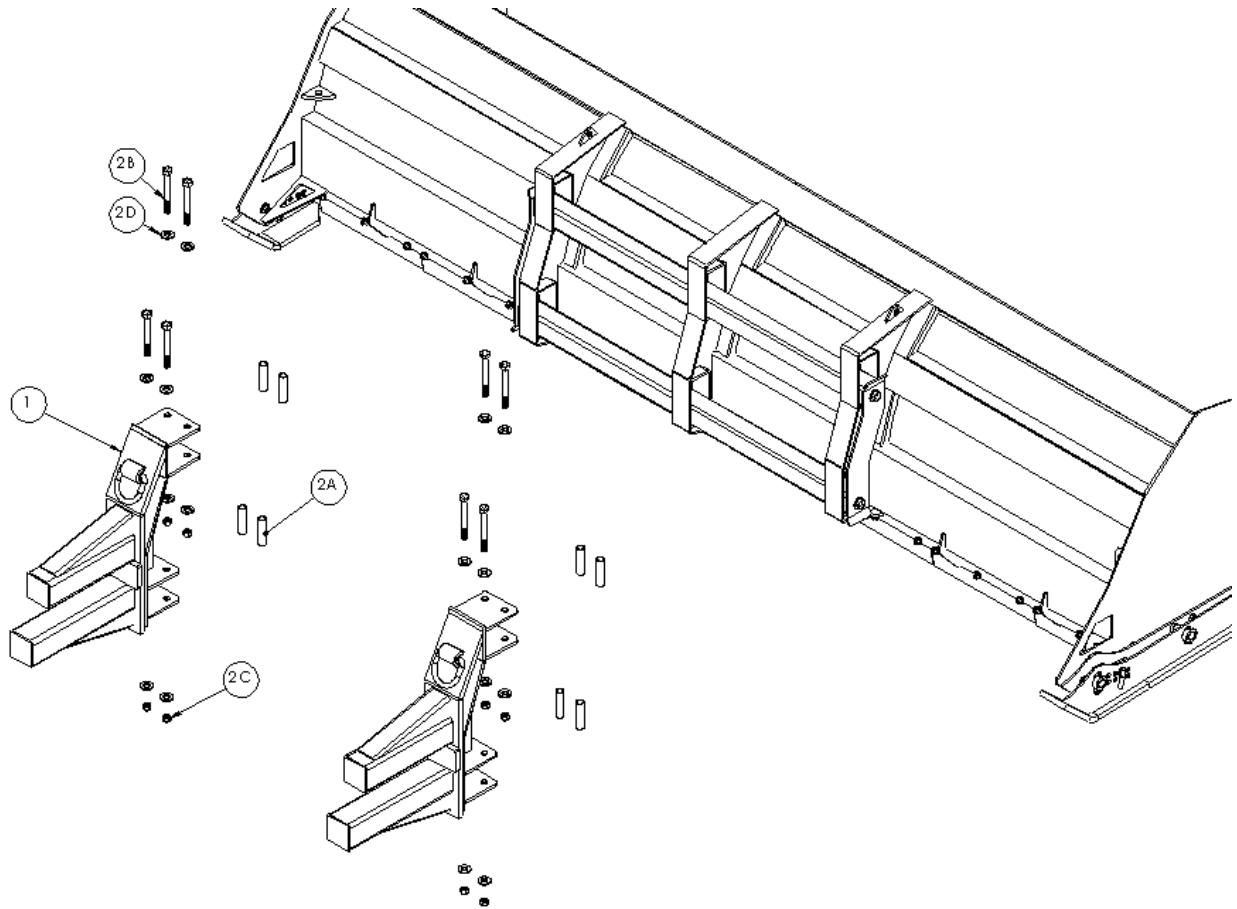

CONNECTION

ITEM	DESCRIPTION	QTY./SET
1	Post Mount Hub Assembly	2
2	Connection Hub Hardware Kit	1
2A	Spacer	8
2B	Bolt	8
2C	Nut	8
2D	Washer	16

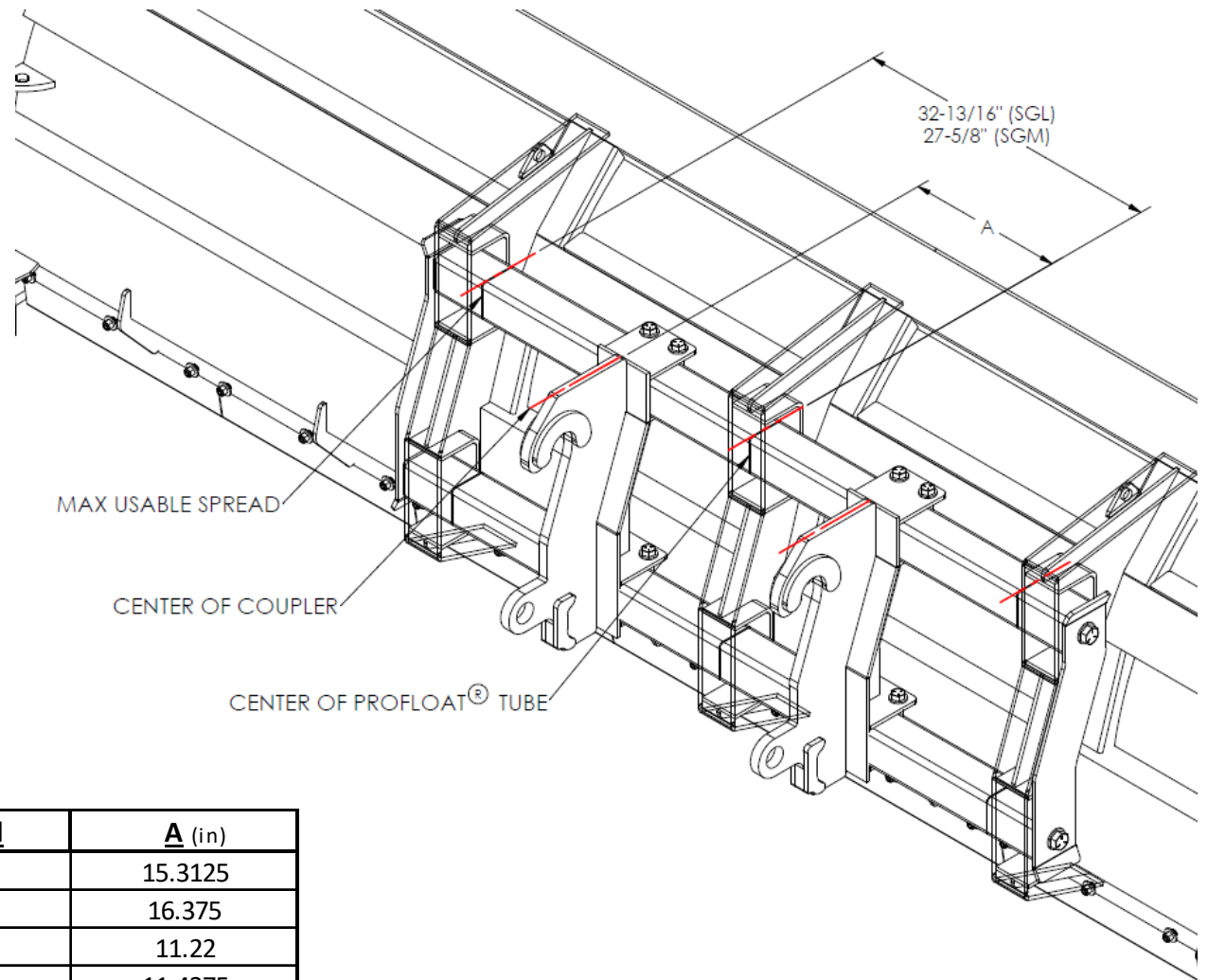

Connection	Model	A (in)
JRB-416	SGL	15.3125
JRB-418	SGL	16.375
CAT-IT 12-28	SGL	11.22
CAT-Fusion	SGL	11.4375
Volvo-L50/L70	SGL	19.6875
Post-Mount	SGL	*
Post-Mount	SGM	*
Universal	SGM	-

*SET POST HUBS TO MAX USABLE SPREAD



SGL and SGM
Owner's Guide